

Lumiglas Sight Glass Fitting Rectangular

The base flange of the sight glass unit is welded into or onto the vessel wall; the glass plate with gasket either side is firmly held in place by bolted on cover flange.

• Application:

For viewing the internals of pipelines, containers, pressure vessels, reactors, silos etc. used principally as a liquid level indicator

• Operating pressure:

Pressure 16 bar

Vacuum

NB: Before putting the fitting into operation, the strength of the cutout reinforcement in combination with the vessel wall should be checked in accordance with TÜV leaflet.

• Operating temperature:

100°C when using sodalime glass, DIN 8903

243°C when using borosilicate glass, DIN 7081

These temperatures refer to unprotected glass (i. e. without mica protective sheet).

• Certification/acceptance test:

If required by customer, and against additional charge, testing and certification can be provided to DIN EN 10204 3.1/3.2

• Parts and available materials in explosion drawing on the right:

item	parts	material options
1	base frame	carbon steel S235JR+N (RSt 37-2); stainless steel 1.4571, 316 Ti or alternative
2	seal	KLINGERSil C-4400; Neoprene; PTFE or alternative
3	sight glass plate	-soda lime glass: thermally prestressed, DIN 8903, max 100°C -borosilicate glass: thermally prestressed, DIN 7081, max 243°C
4	cover frame	steel S235JR+N (RSt 37-2); stainless steel 1.4571, 316 Ti or alternative
5	securing bolts	carbon steel 8.8 or stainless steel A4

• Assembly:

Prior to assembling check the base flange (1) to ensure that the seating for the glass is flat and free from any distortion resulting from welding into/onto the vessel wall. Any distortion or uneven spots can lead to leakage or even breakage of the glass when cover flange is tightened down.

After the base flange (1) is welded correctly, place glass (3) gaskets (2) and cover frame (4) in the order shown in adjoining illustration into the recess of base flange (1) and locate with bolts (5) ensuring all is properly seated when bolts are handtight.

Progressively and carefully tighten down cover flange commencing with bolts in middle of flange and working outwards in crosswise alternating sequence (refer to sequence numbers 1-14 in illustration).

3755.170 c



Complete assembly of a Lumiglas sight glass fitting rectangular

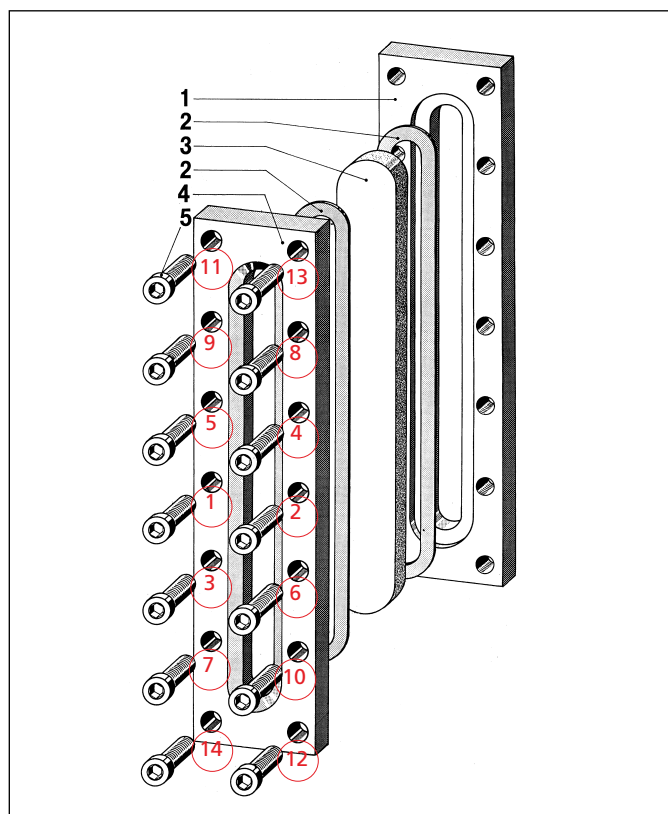

Exploded view of a Lumiglas sight glass fitting rectangular

• Dimensions of Lumiglas sight glass fitting rectangular:

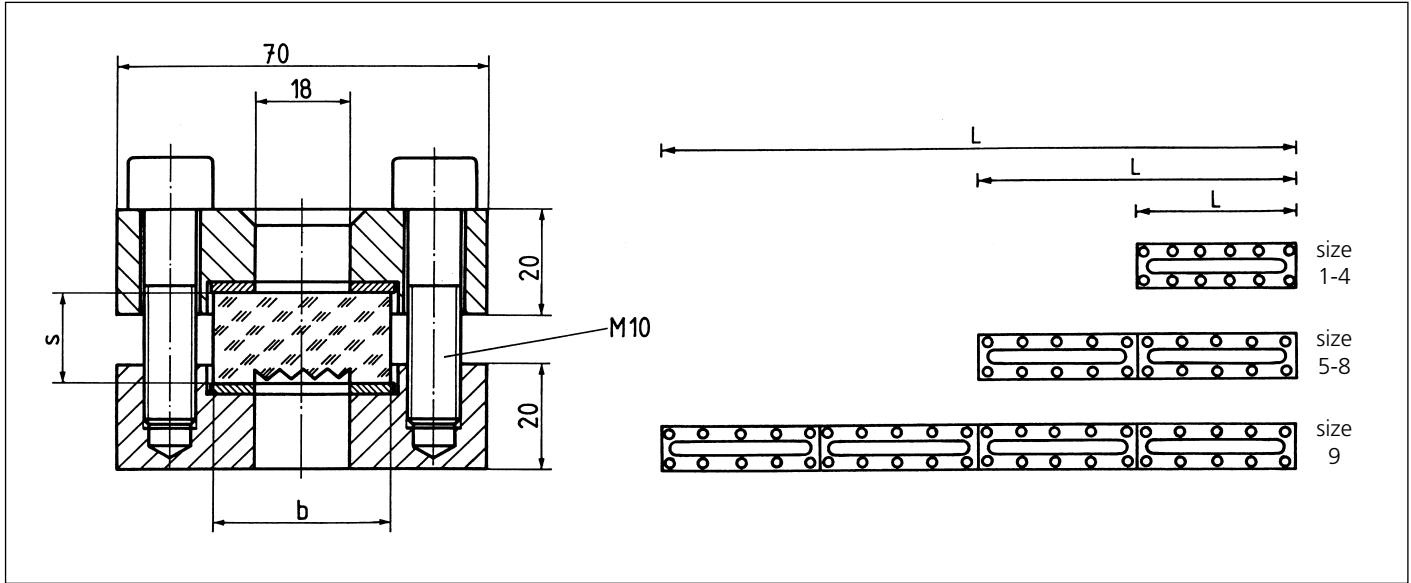

size		1	2	3	4	5	6	7	8	9
fitting	L	250	300	350	400	500	600	700	800	1000
sight glass plate *)	quantity	1	1	1	1	2	2	2	2	4
	/	220	280	320	370	220	280	320	370	220
	b	34	34	34	34	34	34	34	34	34
	s	17	17	17	17	17	17	17	17	17

*) Standard is reflex glass. Please specify in your order if you wish the optionally available transparent type glass.

- The lengths shown under L are the available standard sizes.
- Alternative versions in shape, size and material are available on request.
- External radiusing of the flanges 2 x R is available at extra cost.
- Lumiglas sight glass fitting rectangular are also available with closed base frame (see sketch on the right) for use as external liquid level indicator. In that case the unit is fed via pipes through holes in the base frame plate. The unit comes with such holes suitable drilled or tapped.

• Order data:

Please specify the selected item as follows:

- Lumiglas sight glass fitting rectangular, size: ...
- Length: ...
- Material: base frame; open or closed (plate): ...
cover frame: ...
(when required, each with test certificate type 3.1/3.2)
- Sight glass plate: ...
- Seals: ...

