

## Lumiglas Sight Glass Fitting, Circular DIN 28121 or similar

3755.166 d

Sight glass fittings acc. to DIN 28121 are circular flanged ports that are fastened to welding neck flanges, base flanges or similar by means of bolts.

The fitting is mechanically pre-tensioned as a unit. The structure and dimensions comply with the design standards set out in DIN 28121.

- **Connecting sizes:** PN 10, DN 40 to DN 200
- **Application:**  
For viewing of internals of pressure vessels, tanks, silos, stirred vessels, separators pipelines etc.
- **Operating conditions:**  
Pressure: 10 bar or 25 bar; vacuum  
Temperature: max. 200°C with borosilicate glass DIN 7080  
higher temperatures on request
- **Possible combinations:**  
Can be combined with Lumiglas luminaires when used in **explosion hazardous as well as non explosion hazardous areas**. The Mating flange is then drilled and tapped to suit luminaire mounting bracket.
- **Certificates/testing:**  
Depending on customer requirements and at extra cost, can be provided to DIN EN 10204 3.1/3.2
- **Component materials** shown in adjoining exploded view are
 

item	part	material
1	base flange (version A)	boiler plate H II DIN 17155; stainless steel 1.4571 to DIN 17440 or other
	AB1	sealing rib to DIN EN 1092-1
	AC	tongue to DIN EN 1092-1
	AE	male socket to DIN EN 1092-1
2.1	gasket (side with product contact)	PTFE envelope resilient gasket with corrugated support ring
2.2	gasket (atmospheric side)	KLINGERSil C-4400
3	sight glass disc	borosilicate glass: toughened DIN 7080
4	Mating flange	boiler plate H II, stainless steel 1.4571 or other
5	compression bolts	steel 5.6
- **Installation:**  
Use appropriate fastening bolts, the number and size of which are given on table overleaf, to fit the ready pre-compressed and internally sealed unit to nozzle flange, vessel pad etc.

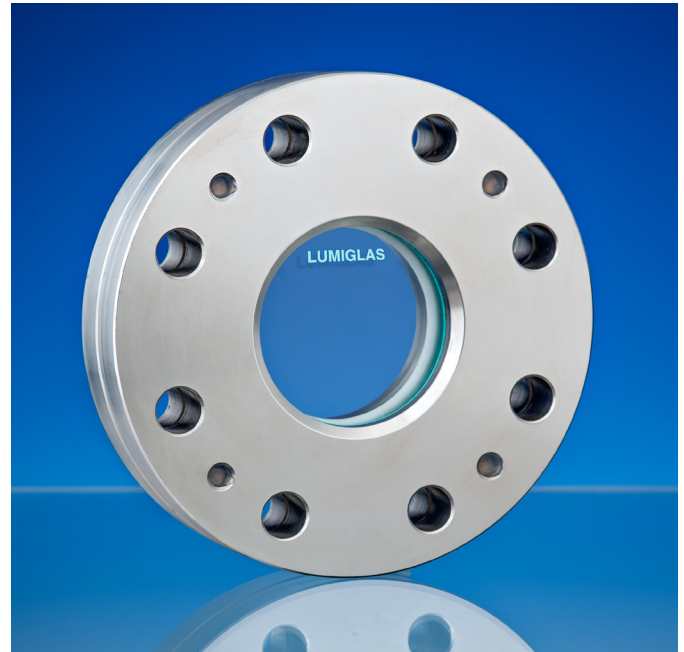

Lumiglas sight glass fitting DIN 28121

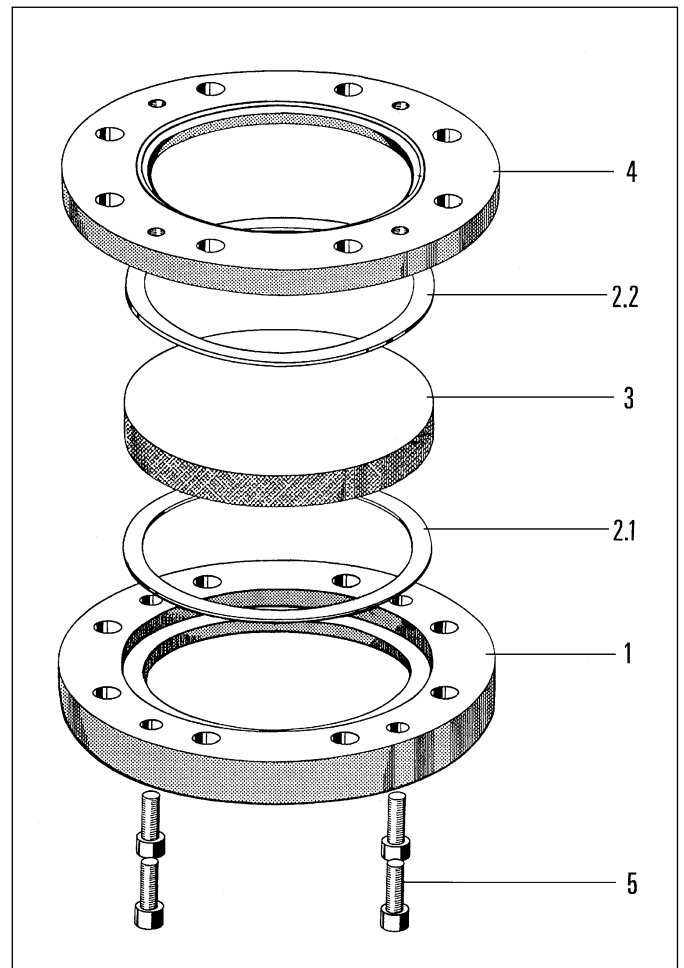

Exploded view of circular sight glass fitting DIN 28121

• Dimensions for Lumiglas sight glass fitting, circular, DIN 28121/PN 10 (version A)

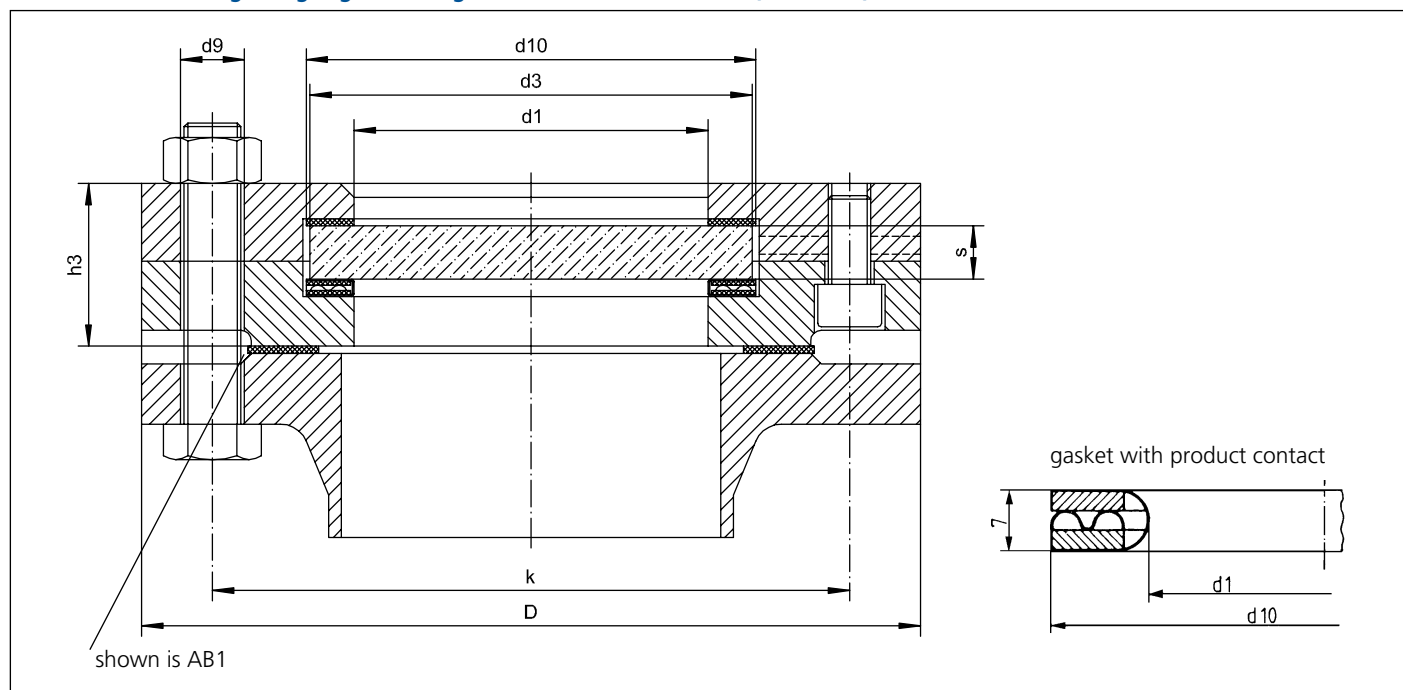

size		1	2	3	4	5	6	7
nominal bore	DN	40	50	80	100	125	150	200
nominal pressure (bar)	PN	10/25	10/25	10/25	10/25	10/25	10/25	10/25
viewing diameter	d1	48	65	80	100	125	125	150
sight glass disc	d3	63	80	100	125	150	150	175
	s	10/12	12/15	15/20	15/25	20/30	20/30	20/30
flanges	D	150	165	200	220/235	250/270	285/300	340/360
	k	110	125	160	180/190	210/220	240/250	295/310
	h3	36/38	38/41	46/50	46/59	54/66	54/66	54/66
fastening bolts (not included in supply)	no.	4	4	8	8	8	8	8/12
	size	M 16	M 16	M 16	M 16/M 20	M 16/M 24	M 20/M 24	M 20/M 24
	d9	18	18	18	18/22	18/26	22/26	22/26
gaskets	d1	48	65	80	100	125	125	150
	d10	65	82	102	127	152	152	177

• Ordering details:

- fitting (DIN) and construction
- nominal bore (DN) / nominal pressure (PN)
- material: base flange (and form of sealing face), test certification 3.1/3.2 on request
- mating flange, test certification 3.1/3.2 on request
- bolts
- glass disc
- gaskets

All dimensions in mm unless stated otherwise. Subject to change without prior notice. 06.16