

Signalling Light BLG LED

Malux
solutions

Compact signalling light in LED technology with solid rubber housing for vibration-proof mounting



Overview

Optical signalling is often required for warning or notifying purposes in areas exposed to vibrations. This is the case e.g. on machines, vehicles, crane installations etc.

The BLG LED Signalling Light is activated by connecting the supply voltage. It is available with different cap colours. The BLG LED has a solid rubber housing providing an ingress protection of IP 67. This makes it suitable for both indoor and outdoor applications.

The LED is provided with the requested cap colour.

Features

- Modern LED technology
- Long lifetime
- Vibration-proof housing
- Protection degree IP 67
- Protection class II
- Continuous, blinking, rotating or flashing light mode selectable by jumper/DIP switch settings
- Flexible use due to different modes

EATON

Powering Business Worldwide

Specifications

Housing	Elastic TPF, cap polycarbonate
Colour	Black
Ingress protection	IP 67 according to EN 60529
Protection class	II (no external equipotential bonding required)
Cable glands	6-8 mm, rubber sealed without strain relief
Connection terminals	1.5 mm ² fine-wire
Operating conditions	Indoors and outdoors
Operating position	Cable entry facing downward
Operation mode	Continuous operation
Temperature range	
Operation	-40 °C to +50 °C
Storage	-40 °C to +70 °C
Weight	Approx. 0.45 kg

General arrangement drawing (all dimensions in mm)

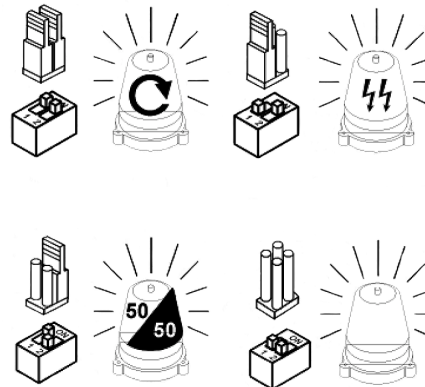
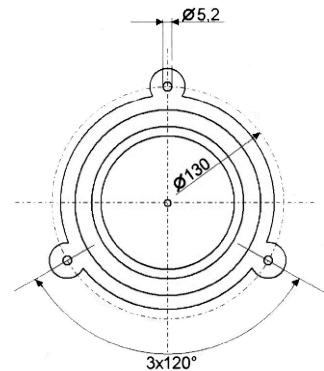
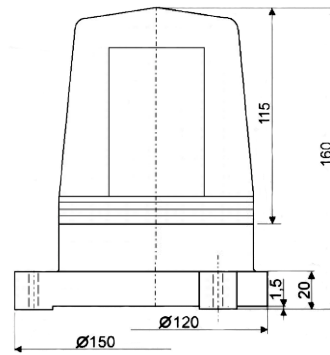

Ordering data

* The full article number is made up by appending the colour code to the article numbers given below.

Type	Designation	Input voltage	Tolerance	Current consumption	Art. No.*
BLG LED	Signalling Light	230 V AC	+5/-5 %	70 mA	FHF 221 507 ..
BLG LED	Signalling Light	12/24 V DC	+5/-5 %	1,2 A/600 mA	FHF 221 513 ..
BLG LED	Signalling Light	230 V AC	+5/-5 %	140 mA	FHF 221 506 ..

transparent	01
red	02
yellow	03
green	04
blue	05